

PIPE SIZING FOR HOT AND COLD WATER

PART TWO - TABULATION METHOD

In Part 1 we looked at the basic principles of pipe sizing. Now to put them into practice we will determine some of the tube diameters required for a proposed refurbishment of a large house into two flats. Each flat containing a kitchen, bathroom, en-suite shower and cloaks WC.

Reference numbers

The first thing to do is to make a drawing of the proposed pipe layout, preferably on scale plans so that measurements of pipe lengths and changes in level can be shown. Then, number each branch and discharge point that needs to be sized, from the water main or cistern, to give an easy reference. For example the section of tube from the water main to the branch entering

flat 1 is referenced 1-2, see Figure 5 hot and cold water systems diagram.

The reference numbers are then transferred to column 1 on the tabulation chart, see Table 2.

Loading units

Next we have to determine the loading units for each referenced pipe, for example: pipe 2-3 serves all the fittings in flat 2 and so has a value of:

<u>Bathroom</u>	
3/4" bath taps	2 @ 10 = 20
1/2"basin taps	2 @ 1.5 = 3
WC cistern	1 @ 2 = 2
<u>En-suite</u>	
Shower	2 @ 3 = 6
<u>Kitchen</u>	
1/2" sink taps	2 @ 3 = 6
15mm w/machine taps	2 @ 3 = 6

Cloaks

Basin spray tap	1 @ 0 = 0
WC cistern	1 @ 2 = 2
Total loading units	45

Pipe 1-2 serves both flats so the loading unit value will be twice the above, 90 loading units.

Pipe 3-4 serves both hot and cold in the shower and bathroom (to give balanced pressures at the shower) as well as hot only in the kitchen and cloaks giving 37 loading units. See Table 4, column 2 for the remainder.

Design flow rate

Using Figure 1, from the previous article, we can convert the loading unit values in column 2 into design flow rates and note these in column 3.

1	2	3	4	5	6	7		9	10	11	12	13	14
						Pipe length (m)	Total head loss						
Pipe reference	Loading units	Design flow rate (l/s)	Assume tube diameter (mm)	Velocity (m/s)	Head loss (m/m)	Pipe length (m)		Total head loss	Vertical drop(+) or rise(-)	Available head	Residual head (11-9)	Residual head required at fitting	Final tube diameter (mm)
1-2	90	1.15	28	2.4	0.22	15	36.2	7.96	-4	26.00	18.04	-	28
2-3	45	0.72	22	2.5	0.33	4	20.4	6.73	-3	15.04	8.31	-	22
3-4	37	0.64	22	2.1	0.25	1	12	3	-	8.31	5.31	-	22
4-5	20.5	0.45	22	1.5	0.13	3.5	9	1.17	-	5.31	4.14	-	22
5-6	14.5	0.38	22	1.2	0.09	2	3	0.27	-1.5	2.64	2.37	1	22
6-7	11.5	0.32	15	2.3	0.48	2	3	1.44	+0.8	3.17	1.73	0.5	15
7-8	10	0.3	15	2.2	0.43	1.5	2.5	1.08	+0.5	2.23	1.16	0.8	15
5-9	6	0.2	15	1.5	0.24	4	5.5	1.32	-	4.14	2.82	0.5	15

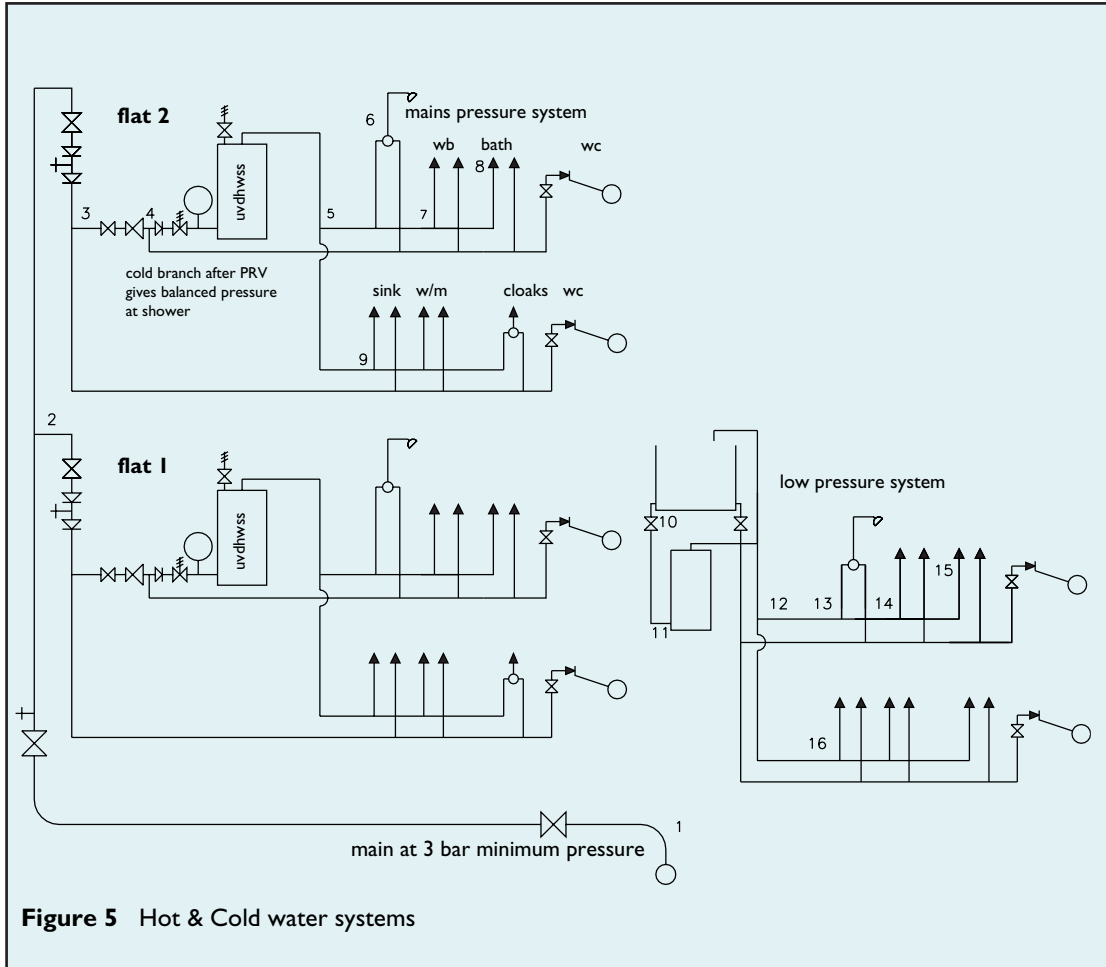

Figure 5 Hot & Cold water systems

Assumed tube diameter

For each referenced section of pipe we have to assume a tube diameter. This is done using Figure 2 from the previous article and a ruler, align the ruler with the tube diameter and flow rate. Check the water velocity is below 3m/s for cold or 2.5m/s for hot. If acceptable note the velocity in column 5 and the head loss in m/m in column 6. For example, pipe reference 1-2 assuming 28mm diameter flowing at 1.15 l/s would give a velocity of about 2.4m/s and a head loss of about 0.22 metres head per metre run. This is repeated for each pipe using the appropriate part of Figure 2, see columns 4, 5 and 6 for the results.

Effective length of tube

Next we need to consider the actual length of tube and the resistances of the installed fittings. Pipe 1-2 is 15m long, this is noted in column 7. It has two stopvalves and two bends fitted. Referring to Table 2 and assuming 28mm diameter tube, the bends have an effective length of 0.6m each whilst the stopvalves have an effective length of 10m giving a total effective length of:

$15 + (2 \times 0.6) + (2 \times 10) = 36.2\text{m}$ this can then be noted in column 8. The process is then repeated for each referenced run of tube.

Note: where it is not possible to forecast the numbers of fittings a percentage (between 10% and 40% depending on the complexity) can be added to the actual length of tube.

The total head loss for each pipe can now be calculated by multiplying the effective length in column 8 by the head loss in column 6. For pipe 1-2 this is: $36.2 \times 0.22 = 7.96\text{m}$ total head loss, the result goes in column 9 and is repeated for each pipe.

Changes in level

Using column 10 we can now note any changes in level. Rises are shown as negative, because head is lost. Drops are positive, as head is gained. For example pipe 1-2 rises 4m from the main to the branch at 2, this is shown as -4m.

Head pressure

Using columns 10, 11, 12 and 13 we can now assess the available head and residual head to see whether the tube

diameters we have assumed will actually give us the flow rate we require.

The initial mains head available is 30m, subtracting the vertical rise of 4m for pipe 1-2 we put 26m available head in column 11 and then subtract the total head loss of 7.96m from column 9. The residual head for this pipe is thus 18.04m, this figure then goes in column 12. The available head for pipe 2-3 is now found by subtracting the vertical rise, 3m, from the previous residual head to give the new available head, this now being 15.04m. Again the total head loss from column 9 is subtracted to give

the new residual head. This process is repeated for each pipe. Remember to add any vertical drops to the residual head figure. See columns 11 and 12 for the remainder. Column 13 is used to indicate the minimum residual head required at a discharge point. A typical shower will require a minimum of 1m head whilst a basin tap needs 0.5m and a bath tap 0.8m to give a satisfactory discharge.

Final tube diameter

If the residual head at any discharge point is less than that required, or if the head becomes negative, it is necessary to select a larger diameter tube. If there seems to be plenty of head available, as is the case with pipe reference 5-6 supplying the shower, there is scope to consider reducing the diameter, see column 14.