

# GUIDE TO THE SUITABILITY OF COPPER WITH VARIOUS CHEMICALS

Copper is well known for its unrivalled, long-term proven performance. Correctly installed, it gives consistently good results in all types of plumbing and heating installations. But the use of copper isn't just confined to carrying water and natural gas, copper tubes are also widely used in industry to carry a variety of chemical products. This article gives general information on the suitability of copper with various types of water and chemicals.

## Drinking water

Copper is generally highly corrosion resistant to potable water that conforms to EEC directives and WHO guidelines. Copper is not a toxic metal as are lead and mercury for instance, in fact it is a desirable 'trace element' with the human body requiring about 2.5 to 5mg/day to maintain normal health.

## Softened water

Hard waters can be softened to avoid build up of scale in boilers and hot water services by replacing insoluble calcium and magnesium salts with soluble sodium salts. However, softening should

be carried out with care bearing in mind that water regulations do not allow the softening of water to kitchen and drinking water taps. So only cold supplies to hot services should be softened and then only to a minimum total hardness of between 60 and 120 ppm (as  $\text{CaCO}_3$ ).

## Deionised water

Deionised water is equivalent to distilled water, both anions and cations having been removed by ion exchange resins. Deionised water is, to some extent, aggressive to all but the noble metals, (such as gold and platinum). If deionised water is used as a heat transfer fluid, for example in air-conditioning equipment, an appropriate inhibitor, such as benzotriazole, should be added.

## Traditional building materials

It is well known that copper is highly resistant to corrosion by most building materials: brick, plaster and concrete or mortar based on Portland cement do not cause problems. Coke breeze and acid plasters and cements, however, should not be allowed to come into contact with metals as they can, if damp, cause corrosion. Where copper tube has to pass through walls it should be sleeved, see Figure 1. Plastics coated copper tube is available and should be considered for use in potentially aggressive environments.

## Household products

Nitre cake toilet cleaners made from sodium hydrogen sulphate do not cause problems because they do not attack copper. However, cleaners containing

hypochlorites or ammonia can attack copper and should be used with great care. If tube shows evidence of vivid discolouration this could be a sign of the use of strong solutions of ammoniacal bleach. Where vertical runs of tube pass through floors that are likely to be frequently wet-cleaned, such as commercial kitchens and laundries, consider extending the sleeve above the floor finish as shown in Figure 2, or use plastics coated copper tube.

## Disinfection of pipeline systems

Where sodium hypochlorite solutions are used to disinfect copper pipeline systems the strength of solution should be limited to 50ppm free residual chlorine for no more than 1 hour, (the solution must never be left in the pipes overnight) and when the process is complete, the system must be flushed through with fresh water until the free residual chlorine is at the level present in the drinking water supplied. Reference should be made to BS 6700:1997.

## Heating installation corrosion inhibitors

Hydrazine (or nitrite) base corrosion inhibitors are sometimes added to heating installations to avoid galvanic

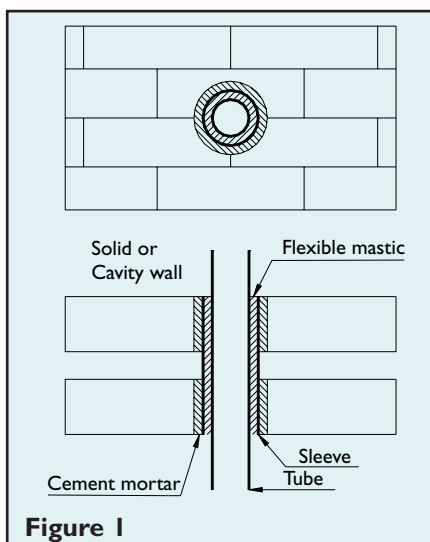
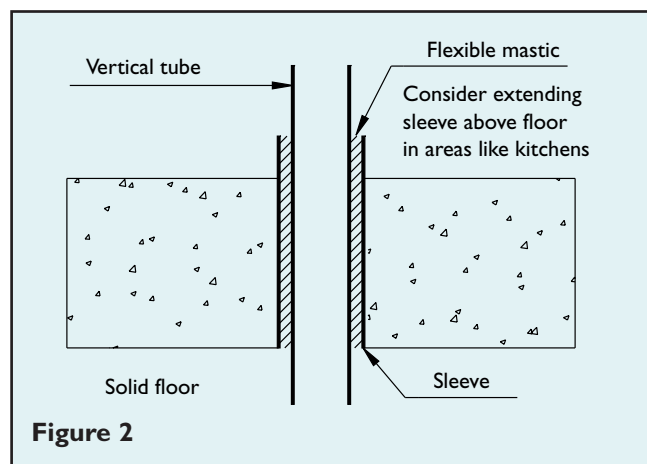

action where mixed metals are used. The inhibitor can be converted to ammoniacal species, by breakdown or reduction, which can cause corrosion of copper or its alloys, (brass). When corrosion occurs, the concentration of the inhibitor is often reduced, but this is precisely the wrong action. Because ammonia is not aggressive to copper in the absence of oxygen and hydrazine is an oxygen scavenger, their concentration should be increased to between 4 and 7 times the value, (in ppm) of the dissolved oxygen content of the water in the system. However, where water treatment is employed it should be carefully controlled and monitored by a suitably qualified expert.

### Various chemical substances

Copper tubes are widely used in industry. Table I gives guidance on the suitability of copper when in contact with a variety of chemicals. These are divided into four groups, (A, B, C, D). Studying the table will show that copper is resistant to corrosion or resists corrosion well when in contact with most chemicals, (groups marked A and B in the Table). Copper will undergo slow corrosion when in contact with the relatively small group of chemicals marked C. Copper is not recommended in the presence of a few substances, (marked D in the Table) these being mainly acids.

**Table I Suitability of copper with various chemical substances**

Acetic (Acid)	B	Chromic Acid	D	Oxalic Acid	C	
Acetic (Anhydride)	B	Cider	A	Oxygen **	A	
Acetone	A	Citric Acid	C	Oxygenated Water	B	
Acetylene (See note)	D	Coffee	A	Palmitic Acid *	B	
Alcohols	A	Copper Chloride	C	Paraffin Wax	A	
Alum	B	Copper Nitrate	C	Phosphoric Acid	C	
Alumina	A	Copper Sulphate	B	Potash	B	
Aluminium Chloride	B	Corn Oil *	A	Potassium Carbonate	B	
Aluminium Hydroxide	A	Cottonseed Oil *	A	Potassium Chloride	B	
Aluminium Sulphate	B	Creosote	A	Potassium Chromate	B	
Ammonia gas (Dry)	A	Crude Oil (Low Sulpher)	A	Potassium Cyanide	D	
Ammonia gas (Wet)	D	Drinking Water	A	Potassium Sulphate	A	
Ammonium Hydroxide	D	Ethers	A	Propane	A	
Ammonium Chloride	D	Ethyl Acetate	A	Rosin	A	
Ammonium Nitrate	D	Ethyl Chloride	B	Sea water	C	
Ammonium Sulphate	D	Ethylene Glycol (Inhibited)	A	Silver Salts	D	
Amyl Acetate	A	Ethyl Alcohol	A	Soap (Solutions of)	B	
Amyl Alcohol	A	Ferric Chloride	D	Sodium Bicarbonate	B	
Aniline	D	Ferric Sulphate	D	Sodium Bisulphate	B	
Aniline (Dyes)	C	Ferrous Chloride	C	Sodium Bisulphite	B	
Asphalt (Dry)	A	Ferrous Sulphate	C	Sodium Carbonate	B	
Atmosphere (Industrial)	A/B	Fluorosilicic Acid	C	Sodium Chloride	B	
Atmosphere (Marine)	C	Formaldehyde	B	Sodium Chromate	B	
Atmosphere (Rural)	A	Formic Acid	B	Sodium Cyanide	D	
Barium Carbonate	A	Freon	A	Sodium Hypochlorite	C	
Barium Chloride	B	Fruit Juice	B	Sodium Nitrate	B	
Barium Hydroxide	A	Fuel Oil	A	Sodium Peroxide	C	
Barium Sulphate	A	Furfural	B	Sodium Phosphate	B	
Barium Sulphide	C	Gasolene	A	Sodium Silicate	A	
Benzene	A	Gelatine	A	Sodium Sulphate	A	
Benzine	A	Glucose	A	Sodium Sulphide	C	
Benzoic Acid	D	Glue	B	Sodium Hyposulphite	D	
Beer	A	Glycerine	A	Solvents for varnish	A	
Bordeaux Mixture	A	Hydrobromic Acid	D	Steam	A	
Borax	A	Hydrocarbons (Pure)	A	Stearic Acid *	B	
Boric Acid	A	Hydrochloric Acid	D	Sugarbeet (Syrup)	A	
Brine	C	Hydrocyanic Acid	D	Sulphur (Dry)	B	
Bromine (Dry)	A	Hydrofluoric Acid	D	Sulphur (Molten)	D	
Bromine (Wet)	C	Hydrogen	A	Sulphur Chloride (Dry)	A	
Butane	A	Hydrogen Sulphide (Dry)	A	Sulphurous Anhydride (Dry)	A	
Butyl Alcohol	A	Hydrogen Sulphide (Wet)	D	Sulphurous Anhydride (Wet)	B	
Butyric Acid	B	Kerosene	A	Sulphuric Anhydride (Dry)	A	
Calcium Chloride	C	Lacquers	A	Sulphuric Acid (80/95%)	D	
Calcium Disulphide	B	Lactic Acid	B	Sulphuric Acid (40/80%)	D	
Calcium Hydroxide	A	Lime	A	Sulphuric Acid (<40%)	C	
Calcium Hypochlorite	C	Linseed Oil *	B	Sulphurous Acid	C	
Cane Sugar Syrup	A	Magnesia	A	Tannic Acid	B	
Carbolic Acid	C	Magnesium Chloride	B	Tar (Dry)	A	
Carbon Tetrachloride (Dry)	A	Magnesium Sulphate	A	Tartaric Acid	C	
Carbon Tetrachloride (Wet)	B	Mercury (and its salts)	D	Toluene	A	
Carbon Dioxide (Dry Gas)	A	Methyl Chloride (Dry)	A	Trichloroacetic Acid	C	
Carbon Dioxide (Wet Gas)	D	Methyl Alcohol	A	Trichloroethylene (Dry)	A	
Castor Oil	A	Milk *	A	Trichloroethylene (Wet)	B	
Caustic Soda	B	Mine Water (Acid)	C	Turpentine	A	
Chlorine (Dry)	A	Natural Gas	A	Varnish	A	
Chlorine (Wet)	D	Nitric Acid	D	Vinegar	C	
Chloroacetic Acid	C	Nitrogen	A	Zinc Chloride	C	
Chloroform	A	Oleic Acid	C	Zinc Sulphate	C	
A = Resistant to corrosion	Note: Home Office Regulations ban the use of copper or copper alloys containing more than 70% copper for carrying acetylene.					
B = Resists corrosion well						
C = Undergoes slow corrosion						* = Product may deteriorate (due to auto-oxidation)
D = Copper is not recommended in the presence of this substance						** = Tubes for carrying oxygen must be grease free.
<b>Source: Copper Development Association</b>						