

# COMPONENT CONNECTIONS

When faced with the need to connect copper tube to plumbing and heating equipment or components the installer has a wide range of alternative fitting types to choose from. The best choice for a particular situation will depend on a number of factors not least of which is the need to use appropriate types of de-mountable joints to facilitate repairs and maintenance.

## Location of servicing and drain valves

To prevent waste of water when work is to be carried out on the system the water regulations demand that stopvalves and servicing valves are installed in certain situations. This is to enable the flow of water to individual or groups of appliances to be controlled and to limit the inconvenience caused during maintenance and repair work.

Servicing valves need to be fitted on the outlet of storage cisterns which have 18 litres capacity or more and they should be fitted as close as possible to the cistern. Regulations also require the fitting of a screwdriver operated servicing valve on the supply to any float operated valve. Figure 1 shows the locations and various types of valve that can be used. Once the location and type of servicing valve has been chosen it

must be installed so that it is accessible.

Note: Servicing valves should NOT be fitted on the cold feed pipe from a feed and expansion cistern to a PRIMARY hot water circuit.

## Hard water scale

In soft water areas spherical plug valves ('ball' type valves) can give satisfactory results when used as service valves. Where hard water scale is expected to form in the system the valve ball can, in time, become trapped by hard scale thus preventing closure. It might be better to use a proper BS 1010 stopvalve in these situations.

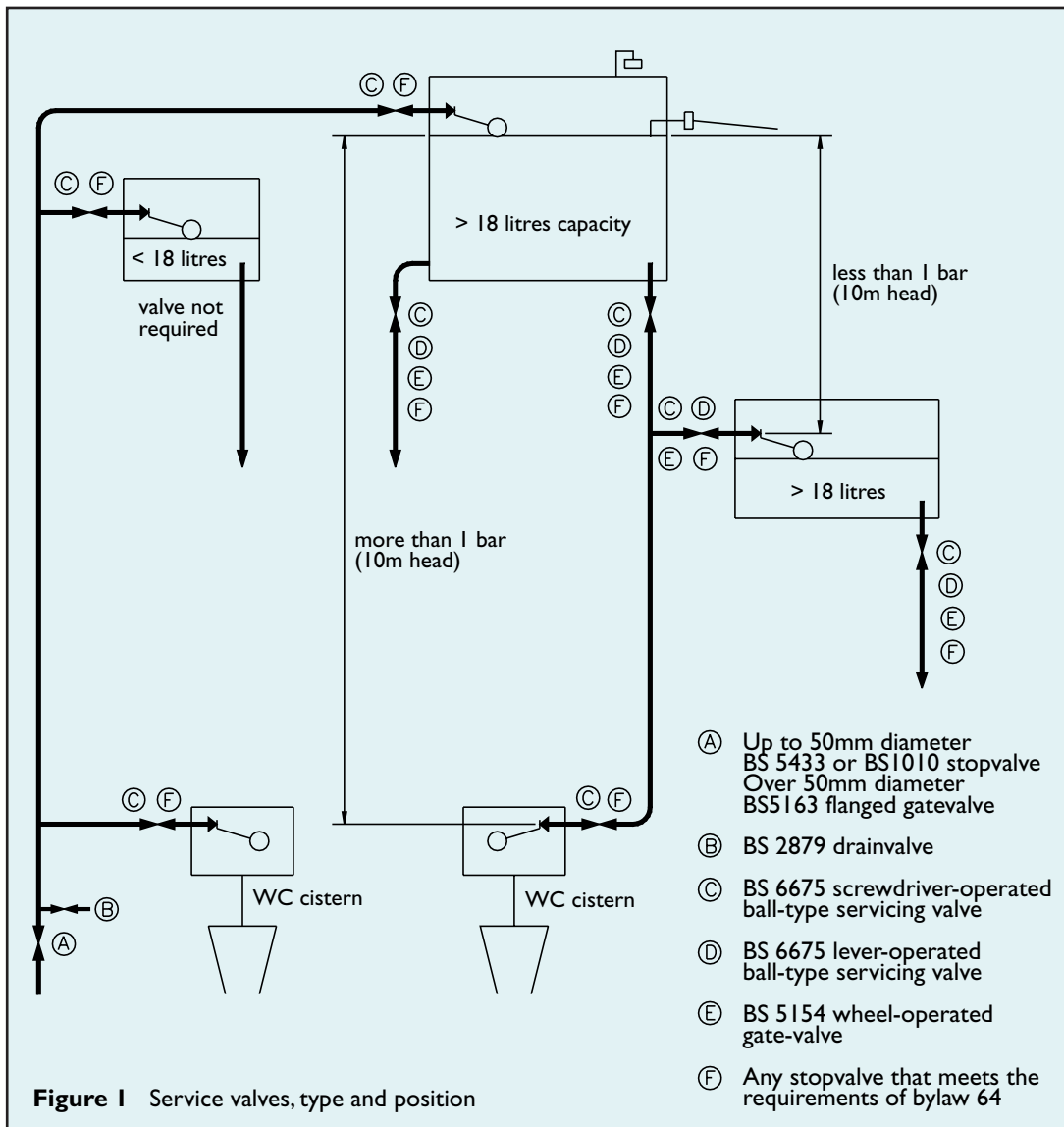

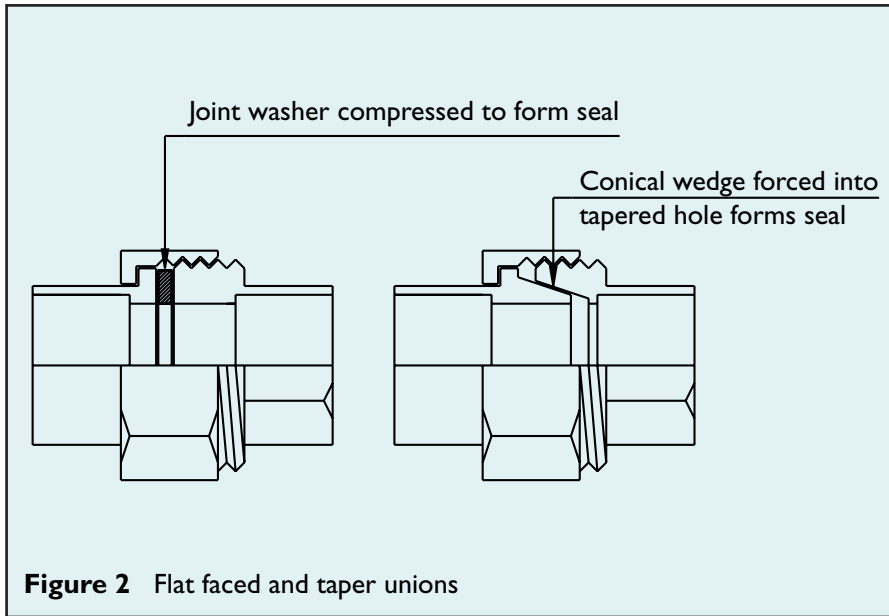

### Gas appliance shut-off valves

When installing appliance shut-off valves on gas lines make sure that you install the valve with its union end downstream. Once the valve is shut the union can be disconnected to remove the appliance burner.

### Unions or compression joints?

When connecting to equipment which might require disconnection on relatively rare occasions, such as on a low-water-content boiler with plain copper tube flow and return connections, then an appropriate pattern of non-manipulative compression joint would allow occasional easy disconnection. On the other hand, where equipment that will require more frequent regular maintenance is to be connected, such as water filters or gas burner controls, the fitting chosen should make use of a purpose designed union which will give better service over the long term even after many disconnections.

### Taper union or flat faced union?

Figure 2 shows the internal features of flat faced and taper unions. Flat faced union joints are similar to flanges or tap connectors and require the compression of an approved fibre or rubber washer to seal the joint. This could be damaged or displaced if care is not taken when aligning and tightening. Taper unions use a different principle, as the taper union is tightened the effect is like a wedge being forced into a tight gap creating a water or gas tight seal without the use of

washers or jointing compounds. Flat faced unions are used to connect components such as circulator pumps. They enable the pump to be removed easily without the necessity to 'spring' apart the connections as would be required if taper unions were used.

### Taper / parallel joint threads

Take care to examine any threads provided by the manufacturer of the equipment. If the thread provided is female it will probably be parallel, if male it could be either tapered or parallel. If a fitting is chosen so that both threads of the joint are parallel then the thread will not tighten as the fitting is assembled so a flanged connector or flat faced union and fibre washer will make a better joint. Where one thread is tapered and the

other parallel then approved jointing material such as PTFE tape on the male thread will be compressed as the tapered male thread is tightened to produce a reliable joint. See Figure 3.

### Long-lasting

Properly installed using approved materials and correct working methods, copper tube and fittings will give many years of trouble-free service. A few moments thought, when choosing a fitting for a particular situation, will pay dividends in the future if essential maintenance jobs are made easier. By using the most suitable type of fitting for the job the professional installer can solve any problem with copper - and rely on the result.

